

Werkzeugkatalog

tool catalogue



APEX

Revolver / turret VDI 30 - DIN 5480

PT - 16



Hinweis zu den AGBs:

Diese finden Sie in unserem Internetauftritt unter

www.heimatec.de

Home/Impressum/AGB

Terms and conditions:

You will find them on our website

www.heimatec.com

Home/Imprint/Terms and Conditions

Das Katalog-Werk einschließlich aller seiner Teile ist urheberrechtlich geschützt. Jede Verwertung außerhalb der engen Grenzen des Urheberrechtsgesetzes ist ohne Zustimmung der Rechteeinhaber unzulässig und strafbar. Das gilt insbesondere für Vervielfältigungen, Übersetzungen, Mikroverfilmungen und die Einspeicherung und Verarbeitung in elektronischen Systemen.

heimatec® GmbH behält sich Änderungen technischer Art jederzeit ohne Vorankündigung vor. Dies gilt insbesondere bei Anpassungen an neue oder geänderte internationale Normen oder bei Weiterentwicklungen unserer Produkte oder Herstellungsprozesse.

This catalogue, including all its parts, is protected by copyright. Each use outside the restricted limitations of the Copyright Act is inadmissible and liable to prosecution without the consent of heimatec. This is particularly valid for duplication, translation, microfilming and feeding and processing in electronic systems.

heimatec® GmbH reserves the right of technical changes everytime without advance notice, which is particularly valid for adaptations to new or changed international standards, or to developments of our products or manufacturing processes.

angetriebene Werkzeuge driven tools



Axial-Bohr- und Fräskopf axial drilling and milling head

$n_{max} = 6000 \text{ min}^{-1}$

8 010 25 090	ER 25	EK	1:1
8 010 25 091	ER 25	IK 25 bar	1:1
8 010 25 118	ER 25 AX u-tec	EK	1:1
8 010 25 119	ER 25 AX u-tec	IK 25 bar	1:1
8 010 26 034	easy quick HT 4	EK	1:1
8 010 26 030	easy quick HT 4	IK 25 bar	1:1



Axial-Bohr- und Fräskopf axial drilling and milling head

$n_{max} = 24000 \text{ min}^{-1}$

8 013 24 022	ER 16 AX u-tec	EK	1:4
8 013 24 030	ER 16 AX u-tec	IK 70 bar	1:4



Axial-Fräskopf axial milling head

$n_{max} = 6000 \text{ min}^{-1}$

8 011 24 012	Kombidorn/universal arbor 16	EK 1:1	
8 011 25 008	Kombidorn/universal arbor 22	EK 1:1	



Axial-Bohr- und Fräskopf axial drilling and milling head

Achsversatz / offset $A=34,5$
 $n_{max} = 12000 \text{ min}^{-1}$

8 016 25 003	ER 25	EK	1:2
8 016 25 000	ER 25	IK 25 bar	1:2
8 016 26 001	easy quick HT 4	EK	1:2
8 016 26 000	easy quick HT 4	IK 25 bar	1:2



Winkel-Bohr- und Fräskopf radial drilling and milling head

Mittenmaß / center distance $H=85$
 $n_{max} = 6000 \text{ min}^{-1}$

8 036 25 008	ER 25	EK	1:1
8 036 25 038	ER 25	IK 140 bar	1:1
8 036 25 039	ER 25 AX u-tec	EK	1:1
8 036 25 040	ER 25 AX u-tec	IK 140 bar	1:1
8 036 26 037	easy quick HT 4	EK	1:1
8 036 26 038	easy quick HT 4	IK 140 bar	1:1

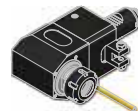
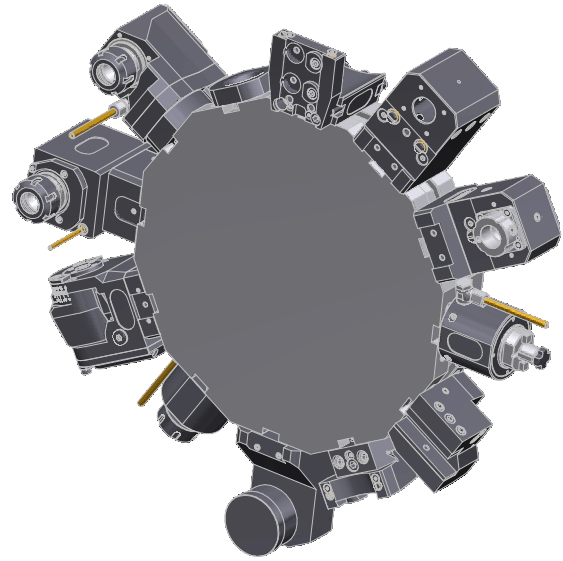

Winkel-Bohr- und Fräskopf radial drilling and milling head

Mittenmaß / center distance $H=100$
 $n_{max} = 6000 \text{ min}^{-1}$

8 036 25 003	ER 25	EK	1:1
8 036 25 002	ER 25	IK 140 bar	1:1
8 036 25 041	ER 25 AX u-tec	EK	1:1
8 036 25 042	ER 25 AX u-tec	IK 140 bar	1:1
8 036 26 039	easy quick HT 4	EK	1:1
8 036 26 000	easy quick HT 4	IK 140 bar	1:1



Winkel-Bohr- und Fräskopf radial drilling and milling head

Mittenmaß / center distance $H=85$
 $n_{max} = 6000 \text{ min}^{-1}$

8 036 24 027	Kombidorn/universal arbor 16	EK 1:1	
8 036 25 043	Kombidorn/universal arbor 22	EK 1:1	



Winkel-Bohr- und Fräskopf radial drilling and milling head

Mittenmaß / center distance $H=100$
 $n_{max} = 6000 \text{ min}^{-1}$

8 036 24 028	Kombidorn/universal arbor 16	EK 1:1	
8 036 25 044	Kombidorn/universal arbor 22	EK 1:1	

► Weitere Ausführungen auf Anfrage
further versions on request

► Zubehör **ZB...***
accessories **ZB...***

► easy-quick

► u-tec



Winkel-Bohr- und Fräskopf radial drilling and milling head

Mittenmaß / center distance H=85
doppelspindlig / double spindle
 $n_{max} = 6000 \text{ min}^{-1}$

8 039 25 054	ER 25	EK	1:1
8 039 26 025	easy quick HT 4	EK	1:1



Winkel-Bohr- und Fräskopf radial drilling and milling head

Mittenmaß / center distance H=100
doppelspindlig / double spindle
 $n_{max} = 6000 \text{ min}^{-1}$

8 039 25 053	ER 25	EK	1:1
8 039 26 026	easy quick HT 4	EK	1:1



Schwenkkopf universal head

Mittenmaß / center distance H=64
 $n_{max} = 6000 \text{ min}^{-1}$

8 040 24 041	ER 16	EK	1:1
--------------	-------	----	-----



Schwenkkopf universal head

Mittenmaß / center distance H=88

8 040 25 021	ER 25 AX u-tec	EK	1:1
8 040 25 022	ER 25 AX u-tec	IK 140 bar	1:1
$n_{max} = 6000 \text{ min}^{-1}$			
8 040 24 059	ER 16 AX u-tec	EK	1:2
8 040 24 078	ER 16 AX u-tec	IK 140 bar	1:2
$n_{max} = 12000 \text{ min}^{-1}$			



Winkel-Scheibenfräserkopf radial disk mill head

Mittenmaß / center distance H=96
 $n_{max} = 3000 \text{ min}^{-1}$
Lieferung ohne Fräserwelle / delivery without milling arbor

8 037 29 021	Ø 8 - Ø 22	EK	2,55:1
--------------	------------	----	--------

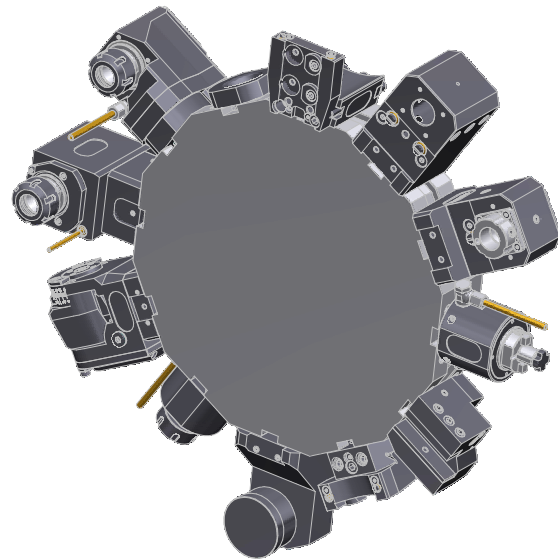

feste Werkzeuge static tool holders



Werkzeughalter C1 tool holder C1

rechts / right

8 214 22 000	Vierkant/square 20/16	EK
--------------	-----------------------	----

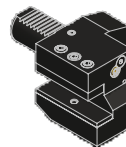

Werkzeughalter C2 tool holder C2

links / left

8 215 22 000	Vierkant/square 20/16	EK
--------------	-----------------------	----

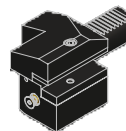

Werkzeughalter C3 tool holder C3

rechts / right

8 214 22 001	Vierkant/square 20/16	EK
--------------	-----------------------	----

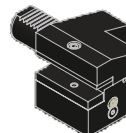

Werkzeughalter C4 tool holder C4

links / left

8 215 22 001	Vierkant/square 20/16	EK
--------------	-----------------------	----



Kombi-Doppel-Drehstahlhalter combi double turning holder

8 251 24 002	Vierkant/square 20	EK
--------------	--------------------	----

▶ Weitere Ausführungen auf Anfrage
further versions on request

▶ Zubehör ZB...*
accessories ZB...*

▶ easy-quick 

▶ u-tec 

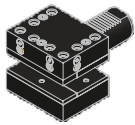

Werkzeughalter D1
tool holder D1

rechts / right

8 274 22 001 Vierkant/square 20 EK

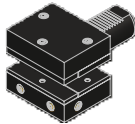

Werkzeughalter D2
tool holder D2

links / left

8 274 22 000 Vierkant/square 20 EK



Vierkant-Mehrfachaufnahme
square multiple holder

8 274 24 000 Vierkant/square 20 EK

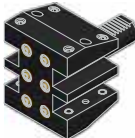

Mehrfach-Drehstahlhalter
multiple turning holder

8 259 22 001 Vierkant/square 20 EK

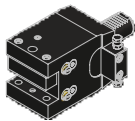

Kombi-Plandrehhalter
combi facing holder

8 234 24 003 Vierkant/square 20 EK

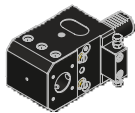

Bohrstangenhalter
boring bar holder

Mittenmaß / center distance H=85
rechts / right

8 230 27 018 $\varnothing 25$ IK/EK

8 230 28 022 $\varnothing 32$ IK/EK

8 230 29 003 $\varnothing 40$ IK/EK



Bohrstangenhalter
boring bar holder

Mittenmaß / center distance H=100
rechts / right

8 230 27 017 $\varnothing 25$ IK/EK

8 230 28 003 $\varnothing 32$ IK/EK

8 230 29 004 $\varnothing 40$ IK/EK

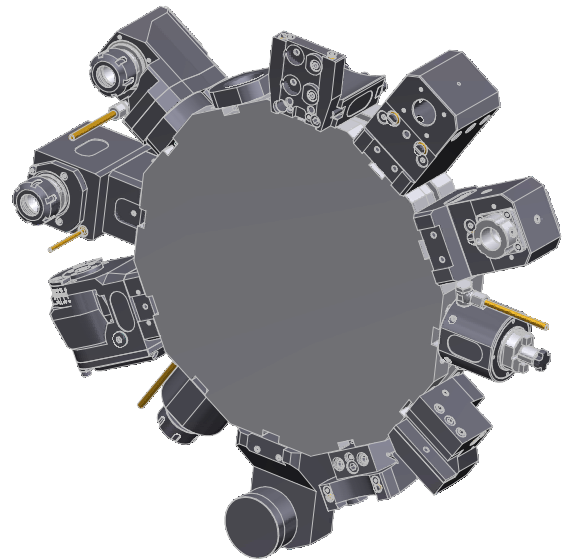

Bohrstangenhalter
boring bar holder

Mittenmaß / center distance H=85
links / left

8 231 27 004 $\varnothing 25$ IK/EK

8 231 28 005 $\varnothing 32$ IK/EK

8 231 29 000 $\varnothing 40$ IK/EK



Bohrstangenhalter
boring bar holder

Mittenmaß / center distance H=100
links / left

8 231 27 003 $\varnothing 25$ IK/EK

8 231 28 006 $\varnothing 32$ IK/EK

8 231 29 001 $\varnothing 40$ IK/EK

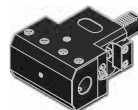

Doppel-Bohrstangenhalter
double boring bar holder

Mittenmaß / center distance H=85

8 239 27 009 $\varnothing 25$ IK/EK

8 239 28 002 $\varnothing 32$ IK/EK

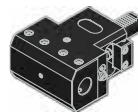

Doppel-Bohrstangenhalter
double boring bar holder

Mittenmaß / center distance H=100

8 239 27 006 $\varnothing 25$ IK/EK

8 239 28 000 $\varnothing 32$ IK/EK

► Weitere Ausführungen auf Anfrage
further versions on request

► Zubehör **ZB...***
accessories **ZB...*** 

► **easy-quick** 

► **u-tec** 

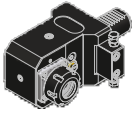
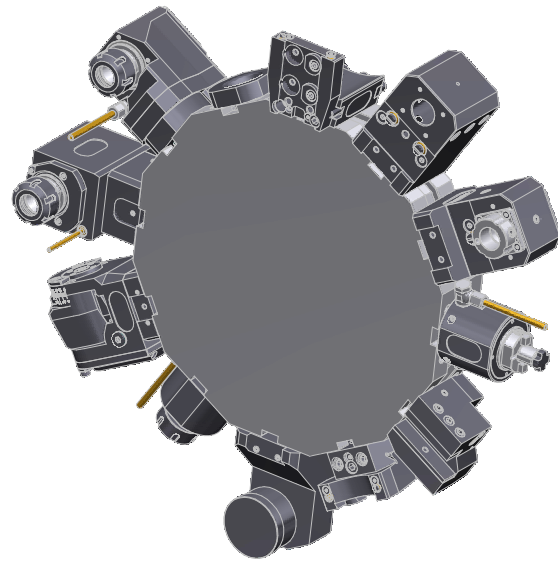

Spannzangenhalter
collet chuck holder

Mittenmaß / center distance H=85
rechts / right

8 230 25 005 **ER 25** IK/EK
8 230 26 008 **ER 32** IK/EK

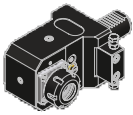

Spannzangenhalter
collet chuck holder

Mittenmaß / center distance H=100
rechts / right

8 230 25 007 **ER 25** IK/EK
8 230 26 009 **ER 32** IK/EK

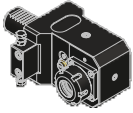

Spannzangenhalter
collet chuck holder

Mittenmaß / center distance H=85
links / left

8 231 25 007 **ER 25** IK/EK
8 231 26 001 **ER 32** IK/EK

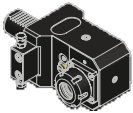

Spannzangenhalter
collet chuck holder

Mittenmaß / center distance H=100
links / left

8 231 25 000 **ER 25** IK/EK
8 231 26 000 **ER 32** IK/EK

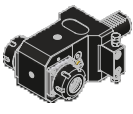

Doppel-Spannzangenhalter
double collet chuck holder

Mittenmaß / center distance H=85

8 239 25 014 **ER 25** IK/EK
8 239 26 006 **ER 32** IK/EK

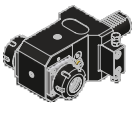

Doppel-Spannzangenhalter
double collet chuck holder

Mittenmaß / center distance H=100

8 239 25 016 **ER 25** IK/EK
8 239 26 007 **ER 32** IK/EK



Aufnahmehalter
tool holder

Mittenmaß / center distance H=85
rechts / right

8 230 26 030 **easy-quick HT 4** IK/EK



Aufnahmehalter
tool holder

Mittenmaß / center distance H=100
rechts / right

8 230 26 023 **easy-quick HT 4** IK/EK



Aufnahmehalter
tool holder

Mittenmaß / center distance H=85
links / left

8 231 26 016 **easy-quick HT 4** IK/EK



Aufnahmehalter
tool holder

Mittenmaß / center distance H=100
links / left

8 231 26 011 **easy-quick HT 4** IK/EK

▶ Weitere Ausführungen auf Anfrage
further versions on request

▶ Zubehör ZB...*
accessories ZB...*



▶ **easy-quick**



▶ **u-tec**





Doppel-Aufnahmehalter
double tool holder

Mittenmaß / center distance H=85

8 239 26 017 **easy-quick HT 4**

IK/EK



Doppel-Aufnahmehalter
double tool holder

Mittenmaß / center distance H=100

8 239 26 013 **easy-quick HT 4**

IK/EK

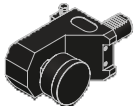

Werkstoffanschlag
stock stop

Mittenmaß / center distance H=85
rechts / right

8 262 29 011 **ø60**

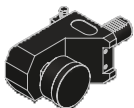

Werkstoffanschlag
stock stop

Mittenmaß / center distance H=100
rechts / right

8 262 29 010 **ø60**

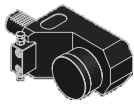

Werkstoffanschlag
stock stop

Mittenmaß / center distance H=85
links / left

8 262 29 012 **ø60**

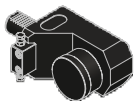

Werkstoffanschlag
stock stop

Mittenmaß / center distance H=100
links / left

8 262 29 028 **ø60**

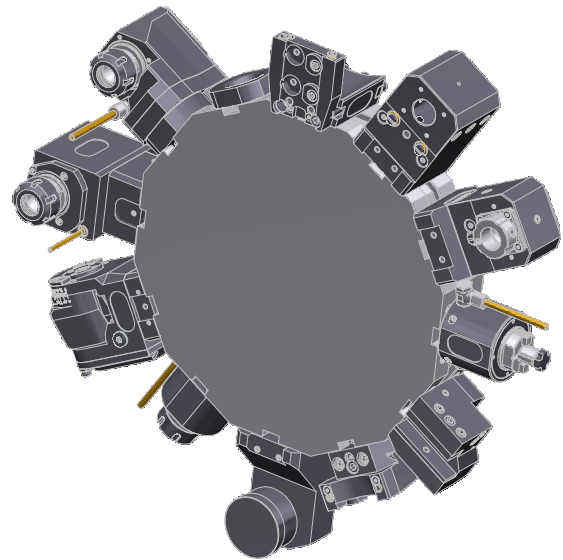

Abstechhalter
cut-off holder

höhenverstellbar / height adjustable

8 320 22 019 **SH 26**

IK 70 bar

8 320 23 013 **SH 32**

IK 70 bar



Abstechhalter
cut-off holder

höhenverstellbar / height adjustable

8 320 29 001 **HORN System 845**

IK 70 bar

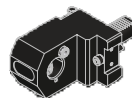

Adapter für VDI
adapter for VDI

Mittenmaß / center distance H=85

8 209 22 000 **VDI 30**

IK/EK

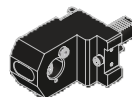

Adapter für VDI
adapter for VDI

Mittenmaß / center distance H=100

8 209 22 011 **VDI 30**

IK/EK





Verschlußstopfen Z2
plug Z2

8 200 20 005 **30 S**

8 200 20 011 **30 K**

► Weitere Ausführungen auf Anfrage
further versions on request

► Zubehör **ZB...***
accessories **ZB...*** 

► **easy-quick** 

► **u-tec** 

- ▶ *easy-quick* HT Schnellwechselsystem
easy-quick HT *fast change system*

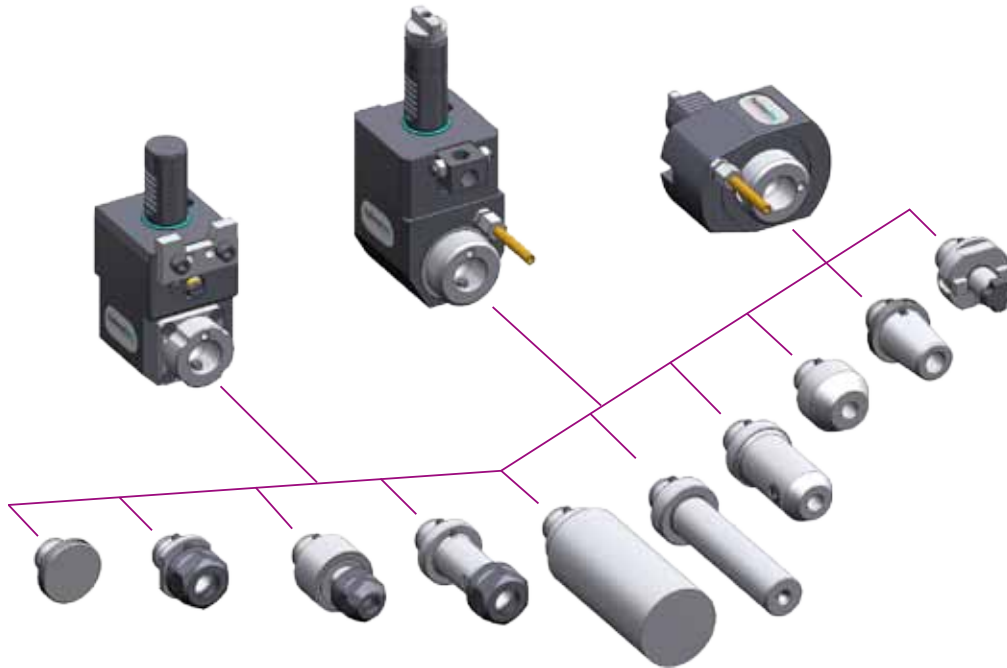

- ▶ Ausführungen siehe Katalog
versions see catalogue

DAS Schnellwechselsystem von heimatec
für angetriebene und feste Werkzeuge

*THE fast change system of heimatec
for driven and static tools*

www.heimatec.de
Produkte / *easy-quick*

www.heimatec.com
products / *easy-quick*



► **u-tec**[®] UT Wechselsystem
u-tec[®] UT change system

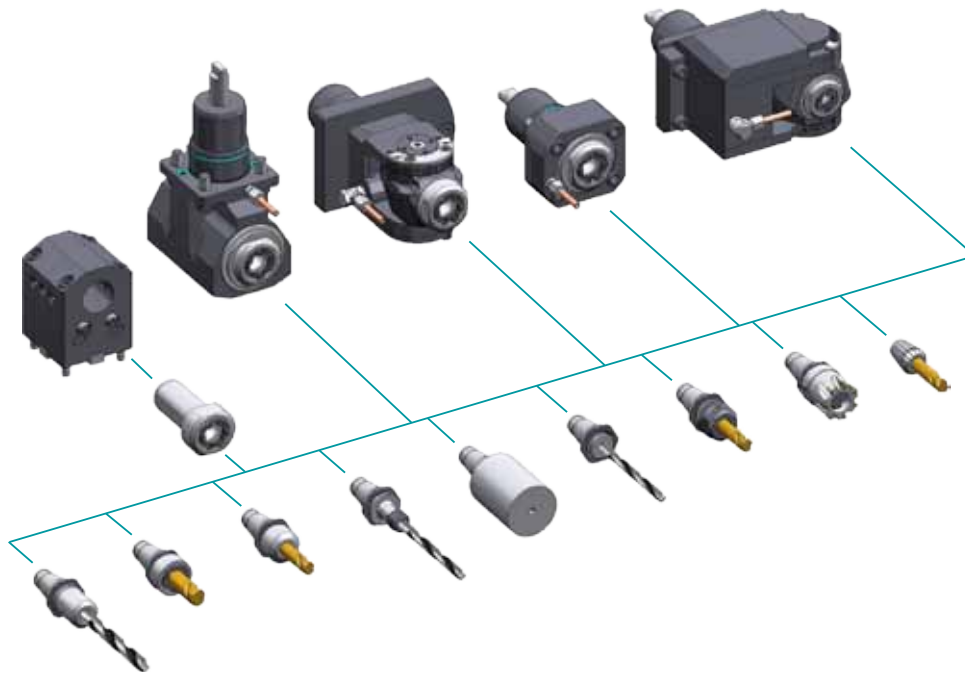

► Ausführungen siehe Katalog
versions see catalogue

Unser Wechselsystem,
das ALLES möglich macht

Our change system,
that makes EVERYTHING possible



www.heimatec.de
Produkte / u-tec

www.heimatec.com
products / u-tec

► **Zubehör**
accessories



► Ausführungen siehe Katalog
versions see catalogue



www.heimatec.de
Produkte / Zubehör

www.heimatec.com
products / accessories

heimatec®

- heimatec®-Niederlassungen
heimatec® overseas branches
- unsere weltweiten Vertretungen
global representations of heimatec®

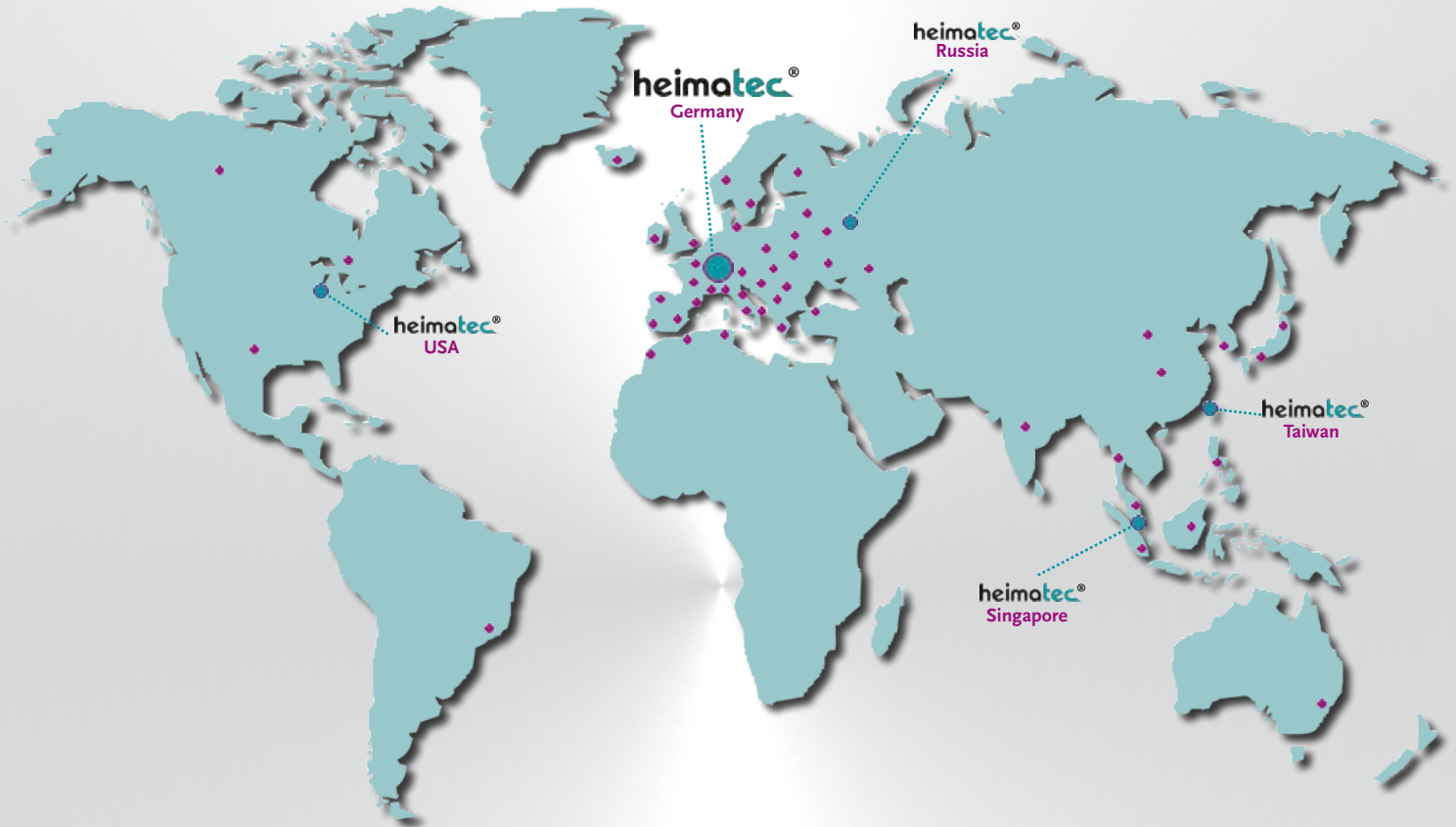

Hauptsitz/headquarters

heimatec® GmbH
Präzisionswerkzeuge
Carl-Benz-Straße 4
D- 77871 Renchen
Postfach 11 36
D- 77867 Renchen
Tel.: +49 (78 43) 94 66 0
Fax: +49 (78 43) 94 66 66
heimatec.de
info@heimatec.de

heimatec® Inc.
USA
usa.heimatec.com
USA@heimatec.com

heimatec®-Ost, JSC
Russia
ru.heimatec.com
Russia@heimatec.com

heimatec® Ltd.
Taiwan
tw.heimatec.com
Taiwan@heimatec.com

heimatec®
Singapore
sg.heimatec.com
Singapore@heimatec.com

